

# Snubbing the FET turn-off voltage in flyback converters

By Robert Kollman  
Senior Applications Manager  
Texas Instruments Inc.

Here's a look at snubbing the FET turn-off voltage in the flyback converter. **Figure 1** shows the flyback converter power stage and the primary MOSFET voltage waveform. This converter operates by storing energy in the primary inductance of a transformer and releasing the energy into the secondary when the MOSFET is turned off.

A snubber is often needed when the MOSFET is turned off as the transformer's leakage inductance will cause the drain voltage to rise above the reflected output voltage ( $V_{reset}$ ). The energy stored in the leakage inductance can avalanche the MOSFET, so a voltage clamping circuit comprised of D1, R24 and C6 is added. The clamp voltage on this circuit is set by the amount of energy in the leakage and the power dissipation in the resistor. A lower value resistor will lower the clamp voltage, but will increase the power loss.

**Figure 2** shows the transformer primary and secondary current waveforms.

On the left is the simplified power stage when the MOSFET is on. The input current ramps up through the series combination of leakage and mutual inductance. The right shows a simplified circuit during the off period. Here the voltage has reversed to the point that the output diode and clamp diode are forward biased. We show the output capacitor and diode reflected to the primary side of the transformer.

The two inductors are in series and are initially carrying the same current when Q1 turns off. That means that there is no current flow in the output diode D2 immediately after turn-off, and the total transformer current flows in

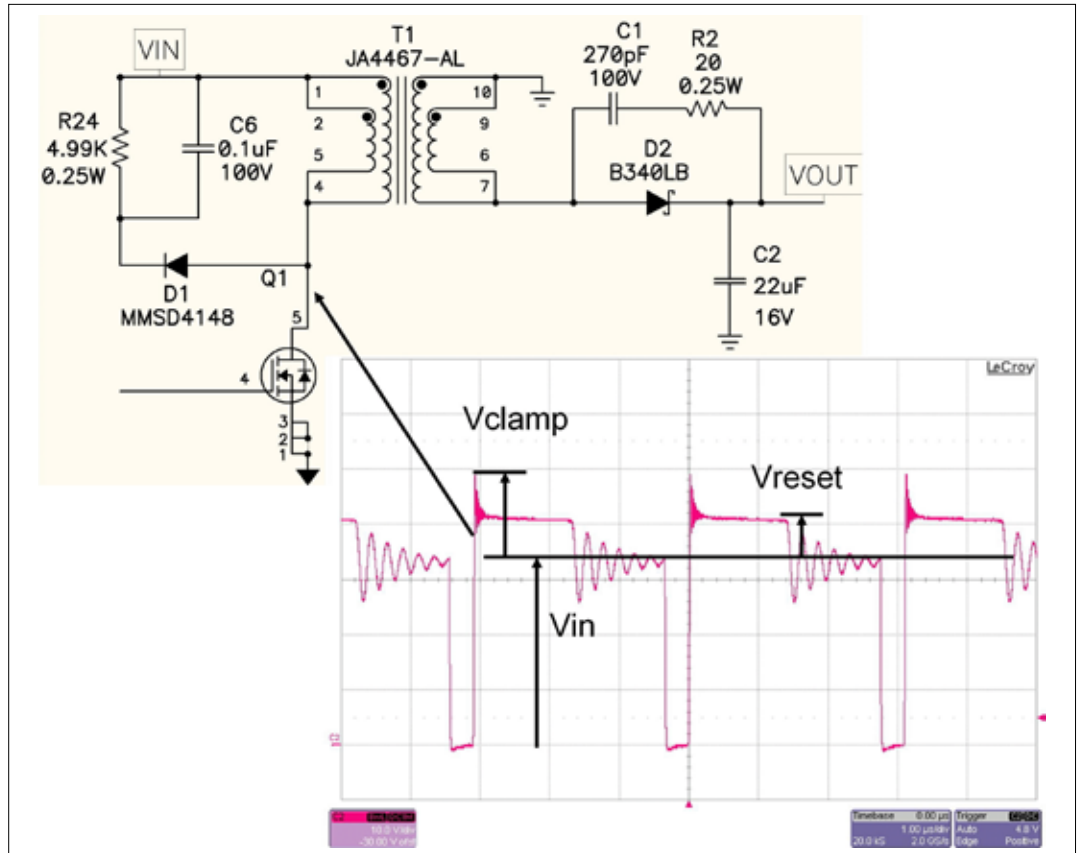

Figure 1: Leakage inductance creates excessive voltage at FET turn-off.

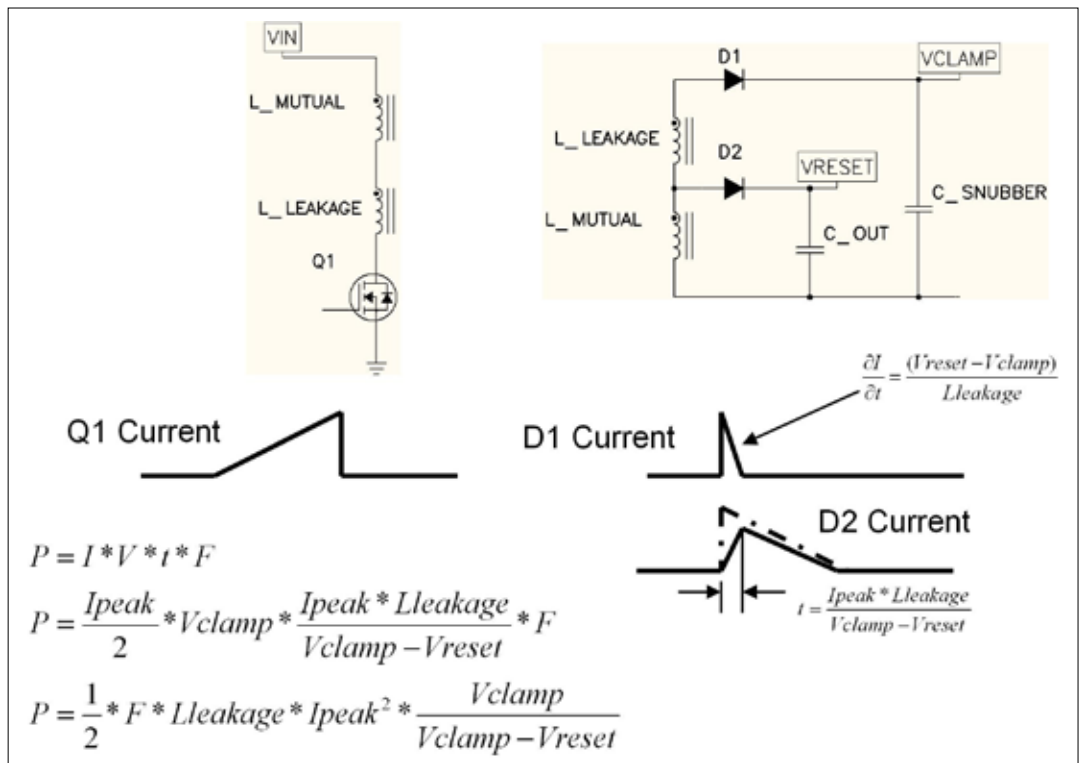

Figure 2: Leakage inductance steals output energy.

D1. The voltage across the leakage inductance is the difference between the clamp and reset voltage, and will tend to discharge the leakage rapidly.

As shown, it is a simple calculation to determine the energy diverted to the snubber. It turns out that you can reduce the diverted energy by reducing the time it takes to discharge the energy in the leakage inductance. This is accomplished by allowing the clamp voltage to increase.

Interesting, you can calculate the trade-off between clamp voltage and snubber power dissipation. As shown in Figure 2, the power put into the clamp circuit is equal to the average clamp diode current times the clamp voltage (assuming a constant clamp voltage). Rearranging some terms we find the term  $\frac{1}{2} \times F \times L \times I^2$ , which relates to the output power of a discontinuous flyback converter. In this case, the inductance is the leakage inductance.

The expression is a little surprising in that the power loss is not just the energy stored in the leakage. It is always greater, but

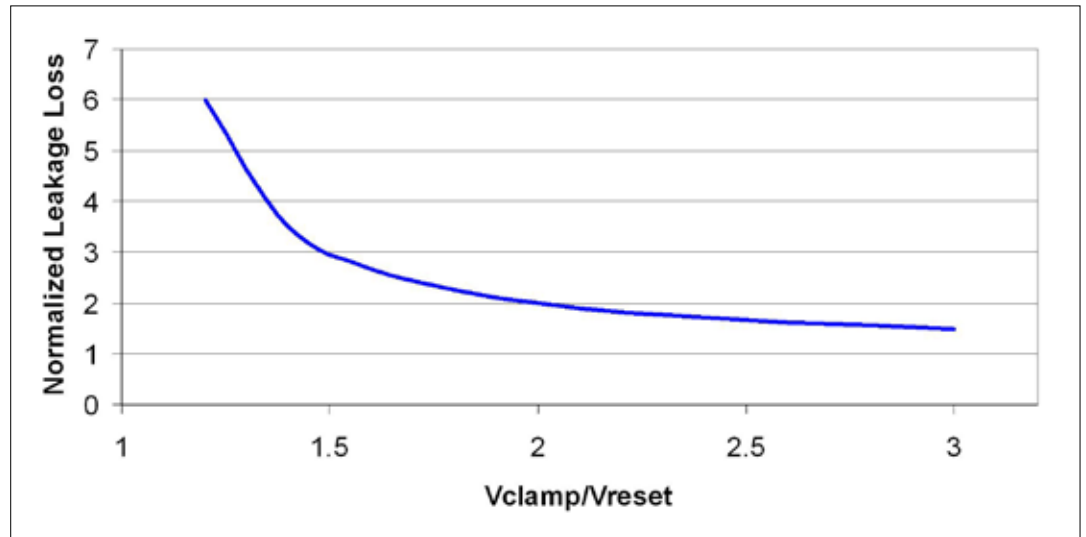

Figure 3: Increasing the clamp voltage reduces snubber loss.

with a dependency on the clamp voltage. **Figure 3** shows this relationship.

The graph plots the loss normalised to the leakage inductance energy loss versus the ratio of the clamp to reset voltage. At high values of clamp voltage, the snubber loss approaches the energy in the leakage inductance. As the clamp voltage is reduced by reducing the resistance, energy is diverted from the main

output and the snubber dissipation is increased dramatically. At a Vclamp/Vreset ratio of 1.5, it is almost three times the loss associated with the leakage inductance stored energy.

Coincidentally, the leakage inductance is often on the order of one per cent of the magnetizing inductance. This makes Figure 3 even more interesting, in that it gives us an indication of the impact on efficiency that lowering

the clamp voltage will have. The vertical axis then just becomes efficiency loss. So reducing the clamp ratio from 2 to 1.5 will have a one per cent efficiency impact.

To summarise, the leakage inductance of a flyback converter can put an unacceptable voltage stress on the power switch. An RCD snubber can control the stress. However, there is a trade-off between the clamp voltage and circuit losses.