

# Understand quasi-resonant, resonant converters

By Jon Harper,  
Fairchild Semiconductor Europe

Higher energy costs, environmental concerns and the issue of sustainability energy sources are driving the European Union (EU) and other various regulatory agencies to focus on reducing the energy wasted by electronic equipment. AC-input power supplies are sources of much of this wasted energy, both under heavy load and in standby.

The efficiency standard for power supplies was, until recently, better than 80 per cent. New initiatives are pushing for efficiencies of 87 per cent and above. In addition, the traditional full-load efficiency measurement is no longer acceptable. It's now the norm to measure efficiency at 25, 50, 75, and 100 of the rated load and to determine the average. Similarly, maximum permissible standby power levels are tightening. The EU is proposing standby power levels of less than 500 mW for all equipment, with less than 200 mW for TVs.

Outside of the realm of special high-efficiency power supply designs, the typical AC-input power supplies used for 1-to-500 watt applications have used the "hard-switched" flyback and the two-switch forward topologies. However, they're being displaced by the quasi-resonant flyback, LLC resonant converter, and asymmetric half-bridge topologies. In this article we'll discuss the difference between quasi-resonant and resonant operation, and the best applications for each.

## Basic principles

Both quasi-resonant and resonant topologies function by reducing the turn-on switching losses in the circuit. Figure 1 shows the differences in the turn-on switch waveforms for a flyback operating

in continuous conduction mode (CCM), a quasi-resonant flyback, and an LLC resonant converter.

The switching losses are, in general, approximated by (Eq. 1):

$$P_{TurnOnLoss} = \frac{1}{2} V_{DS} I_D \cdot t_{ON} \cdot f_{SW} + \frac{1}{2} C_{OSSeff} V_{DS}^2$$

where  $P_{TurnOnLoss}$  is the switching loss,  $I_D$  is the drain current,  $V_{DS}$  is the voltage across the switch,  $C_{OSSeff}$  is the effective value of the output capacitance including stray capacitance,  $t_{ON}$  is the turn-on time, and  $f_{SW}$  is the switching frequency.

The switch losses for the CCM flyback converter are the highest. For a wide-range input voltage design,  $V_{DS}$  will be about 500 to 600 volts, i.e., the sum of the input voltage  $V_{DC}$  and the reflected output voltage,  $V_{RO}$ . When the converter operates in the discontinuous conduction mode (DCM), the first term of the switch losses drops to zero, as the drain current drops to zero. We can further reduce losses in the quasi-resonant converter by switching on the first (or a later) minimum in the voltage waveform. The dotted line in the figure shows the drain waveform when the quasi-resonant converter is switched on the first valley.

If the quasi-resonant flyback converter has a turns ratio of 20, and an output voltage of 5 volts,  $V_{RO}$  will be 100 volts. So for a bus voltage of 375 volts, the switch will turn on at 275 volts. If the effective output capacitance,  $C_{OSSeff}$ , is 73 pF, and the switching frequency,  $f_{SW}$ , is 66kHz, the power loss will be 0.18 watt, i.e., (Eq. 2):

$$P_{TurnOnLossmin} = \frac{1}{2} C_{OSSeff} \cdot (V_{DC} - V_{RO})^2 \cdot f_{SW}$$

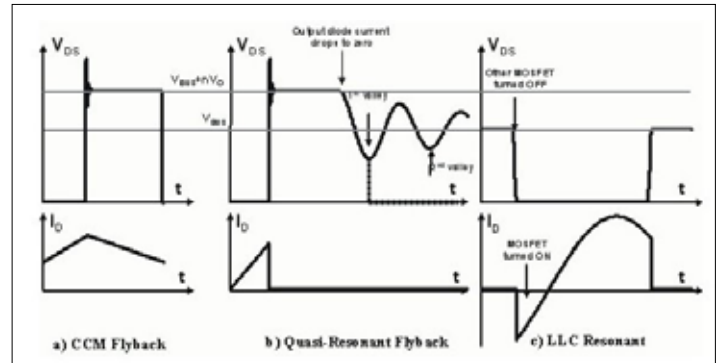

Figure 1: Switching waveforms for the CCM flyback, quasi-resonant flyback, and LLC resonant converters.

For the standard CCM flyback converter, the switching is not synchronised, and the drain voltage rings. In the worst case, the drain voltage is higher than  $V_{DC}$ . The power loss is (Eq. 3):

$$P_{TurnOnLossmax} = \frac{1}{2} C_{OSSeff} \cdot (V_{DC} + V_{RO})^2 \cdot f_{SW}$$

and the resulting loss is 0.54 watt. So for a discontinuous mode flyback converter the power loss fluctuates between 0.18 and 0.54 watt, depending on the timing. Factors affecting the timing are the input voltage and the output current, and favourable factors will result in higher efficiency. This is often seen as unusual variations in the full-load efficiency curves for discontinuous-mode flyback converters. Here the input voltage is varied with a constant output current (and voltage). The efficiency curve will show fluctuations as we move along the switching point. Variations in the primary inductance from lot to lot will also show changes and therefore varying efficiencies.

## Resonant converter

Resonant converters, on the other hand, use a different technique to reduce the switching losses. Returning to the turn-on

loss equation (Eq. 1), if  $V_{DS}$  is set to zero, there will be no losses at all. This principle is known as zero-voltage switching (ZVS). It's used in resonant converters, in particular the LLC resonant converter, as shown in figure 1.

Zero-voltage switching is achieved by forcing the current flowing through the switch to reverse. When the switch current reverses, the body (or external anti-parallel) diode clamps the voltage to a low value (for example, 1 volt). This is far lower than the 400 volts mentioned previously for the typical flyback converter.

A resonant circuit is required to achieve this objective. Two MOSFETs generate a square wave and apply it to the resonant circuit. If we choose the operating point to be above resonance, the current flowing into the resonant circuit will be approximately sinusoidal, as the higher-order components are generally well attenuated. The sinusoidal current waveform lags the voltage waveform. So when the voltage waveform reaches its zero crossing point, the current is still negative, allowing zero-voltage switching.

## Basic topology

Figure 2 shows the circuit and block diagrams for the quasi-resonant, and LLC resonant converters, respectively. The

quasi-resonant converter circuit diagram looks very similar to that of a flyback converter, except that there is a detection circuit to help determine the timing of the voltage minima.

The LLC resonant converter (so named for the three components in the resonant circuit: the magnetizing inductance of the transformer,  $L_m$ ; the transformer's leakage inductance,  $L_k$ ; and the resonant capacitor,  $C_r$ ), is very different from a two-switch forward converter. The required large leakage inductance implies that the transformer be wound in a way to increase its normal leakage inductance, or that the designer add an inductor. The LLC has a half-bridge structure on the primary side, but, unlike a two-switch forward converter, does not need any diodes there. And a resonant capacitor is not used in the two-switch forward converter. There are two output diodes connected to the output of the centre-tapped transformer. These rectify the AC output of the resonant circuit into a DC voltage. There is no need for a large output inductor, which is required for a two-switch forward application.

For a given output power, the size of the quasi-resonant flyback transformer will be the largest, as the converter stores all the energy on the primary side before transferring it to the secondary side. That's not the case for the two-switch forward converter, which transfers the energy from the primary to secondary side when the switches are turned on. Like the flyback converter, the two-switch forward converter uses only one magnetizing polarity. The LLC converter uses both, so all things being equal, it's usually smaller for a given power level.

### Frequency, gain

The benefits of quasi-resonant and LLC resonant switching include reduced turn-on losses. The disadvantage is that the frequency increases as the load decreases. The turn-off losses in both converters become worse with increasing frequency (Eq.4):

$$P_{TurnOffLoss} = \frac{1}{2} V_{DS} I_D \cdot t_{OFF} \cdot f_{SW}$$

where  $t_{OFF}$  is the turn-off time. This reduces the efficiency at lighter loads. Fairchild's FSQ0165RN quasi-resonant FPS power switch, for example, uses special frequency clamp circuitry to offset this inherent disadvantage. The controller waits a minimum time, corresponding to the maximum frequency, and then switches on the next available minimum.

A further limitation of the LLC resonant converter is that the dynamic range of its gain is very limited. Figure 3 shows the gain characteristics of an LLC converter as a function of frequency and load. At an upper resonance frequency (in this case, 100kHz), there is no change in frequency as the load changes. However, the dynamic range of the gain is low, between 1.0 and 1.4. If 1.2 represents the system gain with a 220-VAC input for the desired output voltage, the dynamic range would allow an input voltage range of 189 to 264 VAC. As a result, universal-input operation is not easily achieved with this topology. But, with careful design to allow for hold-up time conditions, it's possible for the typical European mains. LLC resonant converters are generally used with power factor correction stages that provide a well-regulated input voltage to the LLC converter.

The dynamic range of the gain may be improved by increasing the leakage inductance with respect to the magnetizing inductance. The trade-off is reduced light-load efficiency due to higher magnetizing currents. In practice, we increase leakage inductance using a second inductor; there are practical limitations to getting repeatable leakage-to-magnetizing inductance ratios if the leakage inductance is too large.

### Applications

Quasi-resonant flyback and LLC resonant converters are increasingly used in embedded AC-input power supplies. The practical

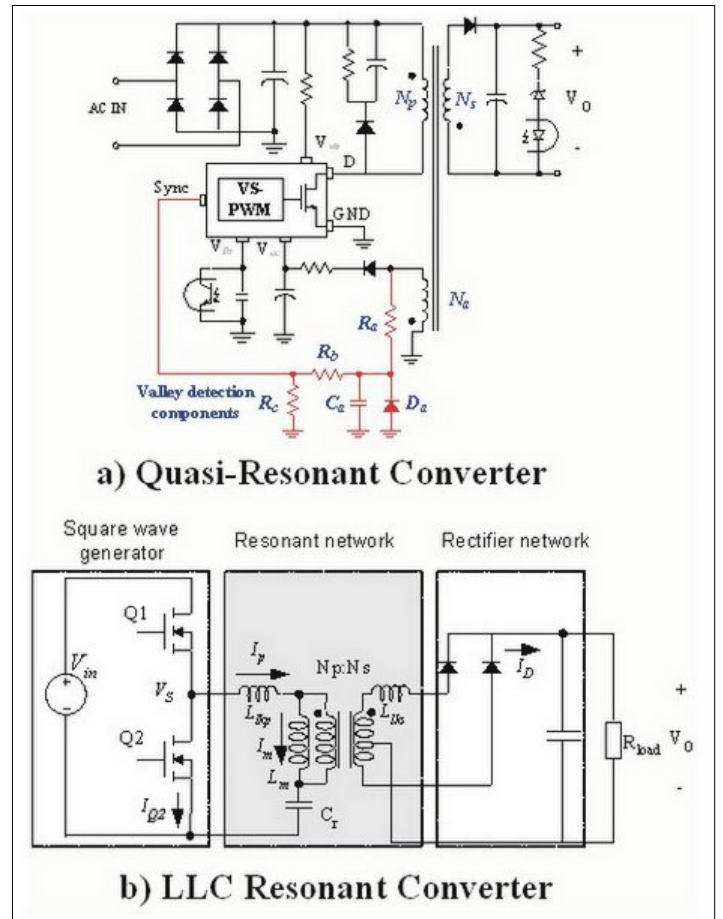

Figure 2: Circuit of quasi-resonant flyback converter; block diagram of LLC resonant converter.

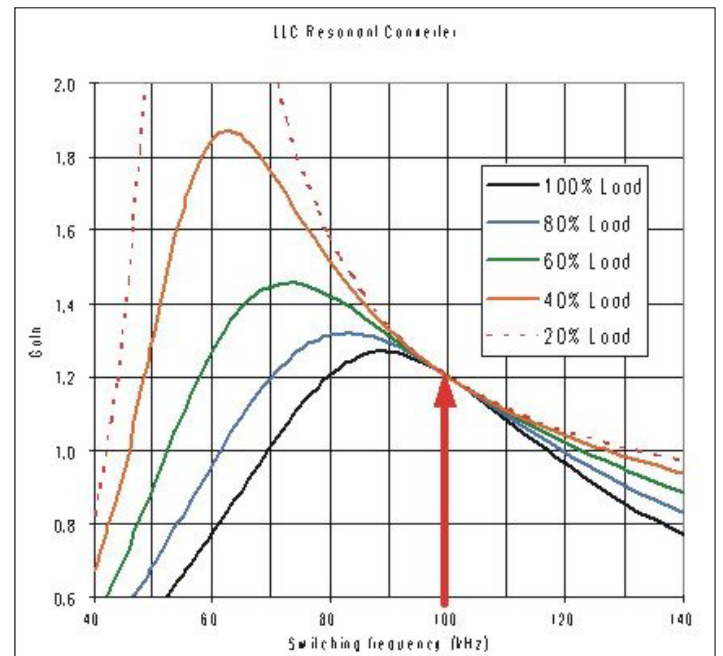

Figure 3: Gain curve, LLC resonant converter.

range of operation for a quasi-resonant converter runs from a few watts to about 100 watts. Full-load efficiency ranges from around 81 per cent for a 7-watt, 12-volt supply for an integrated

solution, to greater than 88 per cent for a 70-watt, 22-volt supply using a quasi-resonant controller with an external MOSFET. The low-power example has a stand-by consumption well below 150

mW; the higher power example has a standby power of less than 350 mW. Using lower output voltages will reduce the efficiency below this level quickly. A 5-watt, 5-volt power supply will waste at least 10 per cent of the rated output power in the output diode.

An additional benefit of the quasi-resonant topology is that the EMI is much less than for a

hard-switched application. The frequency will naturally vary with the ripple on the 400-volt input capacitor, and there will be frequency spectrum spreading. Further, the common-mode EMI noise is reduced as the switching takes place at a lower voltage, reducing the switching noise.

The practical range of operation for LLC resonant converters

ranges from around 70 to 500 watts or so. The FSFR2100 with a PFC front end has been used to implement power supplies from 200 watts up to 420 watts. For applications up to 200 watts, a heat-sink (on the FSFR2100) is generally not needed. Schottky diodes are generally recommended on the output and these will usually need heatsinks.

Synchronous-rectification methods can be used to remove the need for heatsinks. However, the control signals for the MOSFETs are not easy to generate. Typical peak efficiencies for applications using Schottky diodes are in the low to mid 90s, depending on the input voltage, the output voltage and the output power.